

HTB 油路板型油壓缸 LAM. LWM

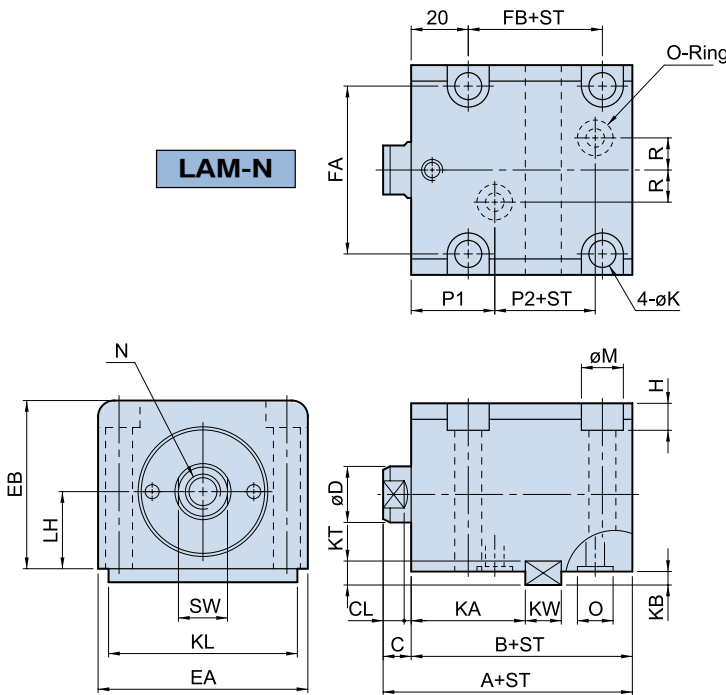

Manifold Type Hydraulic Cylinder LAM.LWM

• Bore: $\phi 32$ - $\phi 63$ mm • Pmax: 140kg/cm²



LAM-N

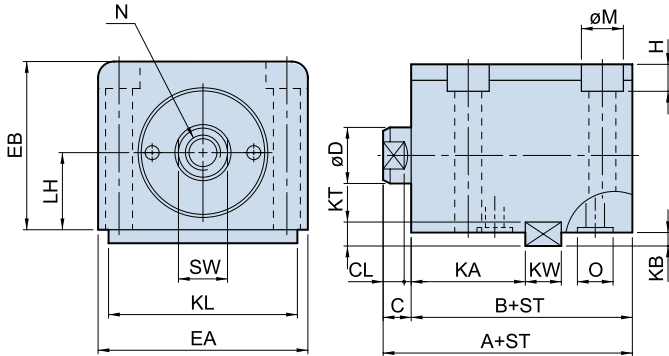

LWM-N

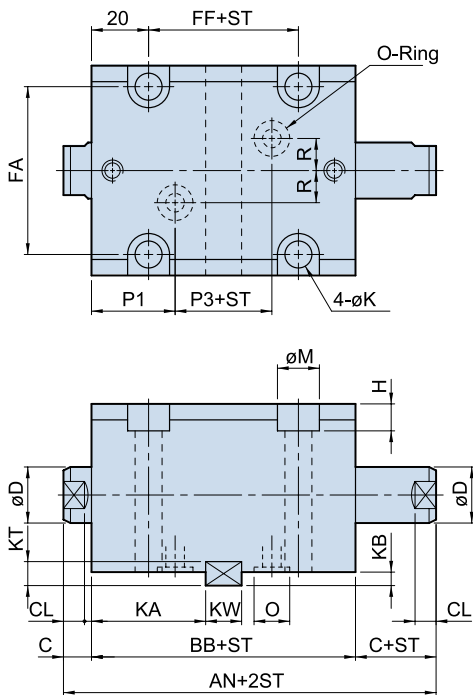

訂購標示法 Ordering Code

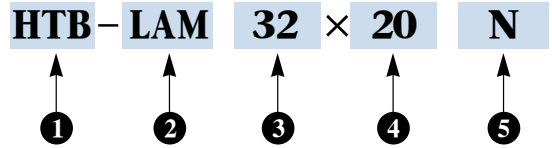

①	系列別 Series	HTB
②	安裝型式 Mounting type	LAM 側向單軸型 Single end rod type LWM 側向雙軸型 Double end rod type
③	油缸內徑 Bore of cylinder	$\phi 32, \phi 40, \phi 50, \phi 63$
④	標準行程 Standard stroke	10, 20, 30, 40, 50
⑤	軸端型式 Rod end type	內牙N: Internal thread N 外牙W: External thread W

註:行程10mm無附鍵槽及平鍵。
Stroke: 10mm without key.

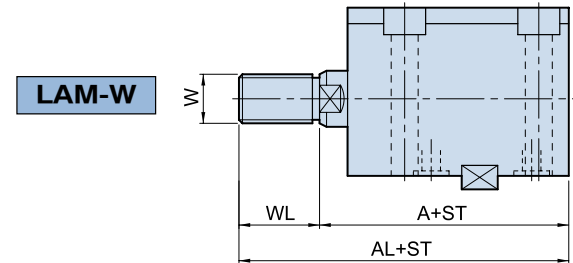

LAM-W

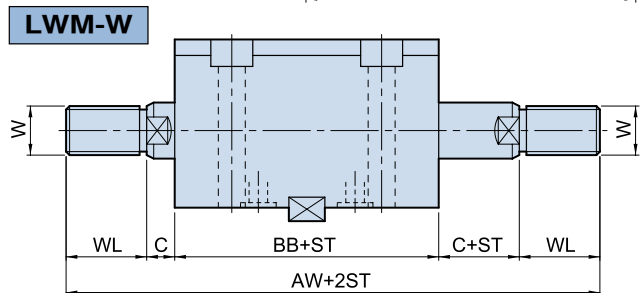

LWM-W

KEY



Key size

UNIT:mm

Bore	KW	KT	KL	KA	KB
$\phi 32$	12	8	63	38	4.5
$\phi 40$	12	8	70	38	4.5
$\phi 50$	14	9	80	40	5
$\phi 63$	16	10	100	42	5.5

ST=Stroke

Dimensional table

右列行程之本體長度B及BB尺寸相同 (5, 10)(15, 20)(25, 30)(35, 40)(45, 50)
The length "B" and "BB" of cylinder body is the same of the stroke: (5, 10)(15, 20) (25, 30) (35, 40) (45, 50)

UNIT:mm

Bore	A	AL	AN	AW	B	BB	C	CL	D	SW	EA	EB	LH	FA	FB	FF	H	K	M	N	W	WL	P1	P2	P3	R	O
$\phi 32$	64	89	89	139	54	69	10	7	20	17	70	56	25	56	24	32	9	9	14	M12x1.75x15D.	M16x1.5	25	28	14	13	10	P9
$\phi 40$	65	95	90	150	55	70	10	7	25	22	80	64	29	62	23	32	11	11	18	M16x2.0x20D.	M22x1.5	30	28	15	14	10	P9
$\phi 50$	71	106	97	167	60	75	11	8	30	27	94	74	34	74	27	35	13	13	20	M20x2.5x25D.	M26x1.5	35	29.5	18	16	10	P11
$\phi 63$	80	120	108	188	67	82	13	10	35	32	114	89	42	90	32	42	15	15	22	M27x3.0x35D.	M30x1.5	40	31	20	20	10	P11

HTB 薄型油壓缸 LA20. LA25



Hydraulic Thin-Type Cylinder

• Bore: $\phi 20$ - $\phi 25$ mm • Pmax: 140kg/cm²

訂購標示法 Ordering Code

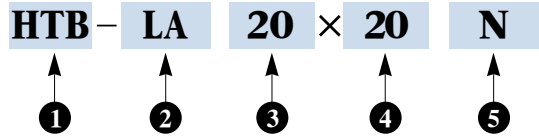

1	系列別 Series	HTB	
2	側向安裝 Side mounting	LA	配管式單軸 Line type (Single end rod)
		LW	配管式雙軸 Line type (Double end rod)
		LAM	油路板單軸 Manifold type (Single end rod)
		LWM	油路板雙軸 Manifold type (Double end rod)
3	油缸內徑 Bore of cylinder	$\phi 20$	$\phi 25$
4	標準行程 Standard stroke	10.20.30.40	10.20.30.40.50
5	軸端型式 Rod end type	內牙N: Internal thread N 外牙W: External thread W	

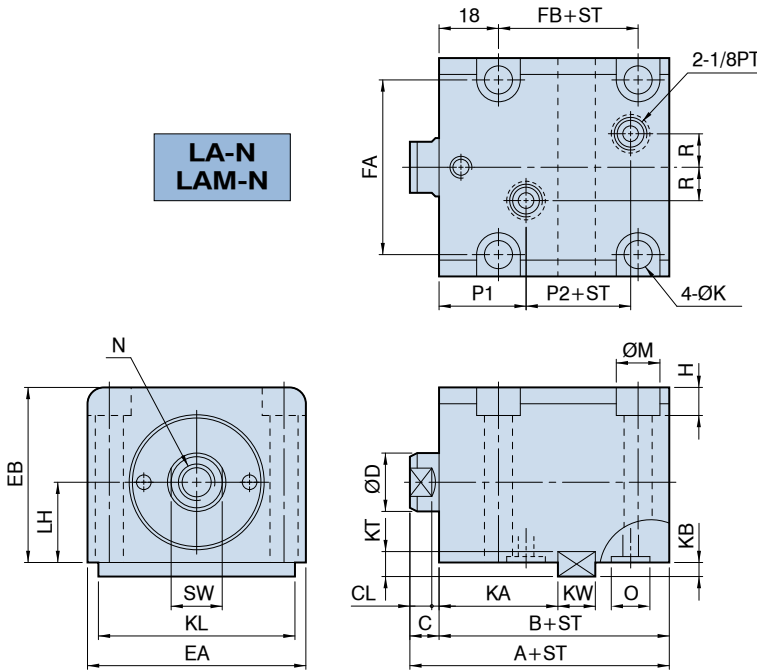

LW-N.LWM-N

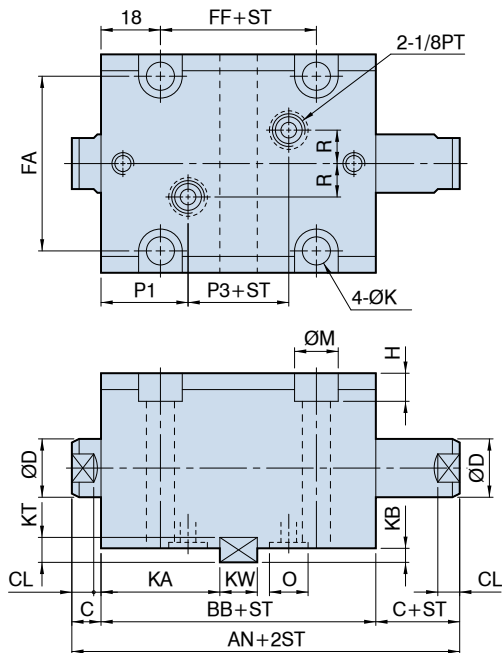

LA-W LAM-W

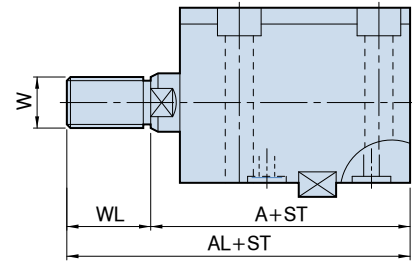

LW-W LWM-W

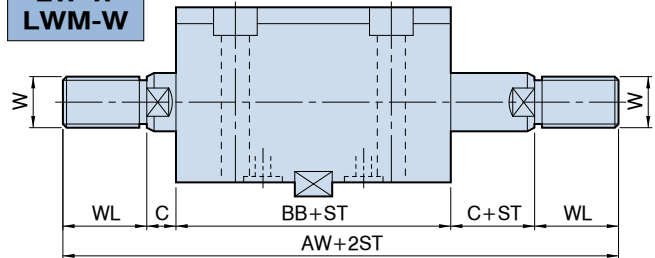

KEY

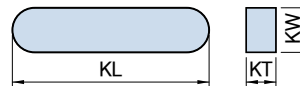

ST=Stroke

Dimensional table

右列行程之本體長度B及BB尺寸相同(5,10)(15,20)(25,30)(35,40)(45,50)
The length "B" and "BB" of cylinder body is the same of the stroke: (5,10)(15,20)(25,30)(35,40)(45,50)

UNIT:mm

Bore	A	AL	AN	AW	B	BB	C	CL	D	SW	EA	EB	LH	FA	FB	FF	H
$\phi 20$	51	71	72	112	43	56	8	6	12	10	46	37	16	35	16	20	6.5
$\phi 25$	53	75	74	118	45	58	8	6	14	12	52	44	20	41	18	22	6.5
Bore	K	M	N	W	WL	P1	P2	P3	R	O	KW	KT	KL	KA	KB		
$\phi 20$	6.8	11	M8x1.25x12D.	M10x1.25	20	22.5	11	11	5	P7	8	7	40	29	3.5		
$\phi 25$	6.8	11	M10x1.5x15D.	M12x1.25	22	23	12	12	7	P7	8	7	45	30	3.5		