

# SP 油壓支撐缸



## Hydraulic Supporting Cylinder

**HSP 高壓支撐缸**  
High pressure supporting cylinder  
Rod:  $\phi 16\text{mm}$   
Pmax:  $500\text{kg/cm}^2$



**HSP 高壓支撐缸**  
High pressure supporting cylinder  
Rod:  $\phi 25\text{mm}$   
Pmax:  $500\text{kg/cm}^2$



**LSP 低油壓支撐缸**  
Low pressure supporting cylinder  
Rod:  $\phi 16\text{mm}$   
Pmax:  $70\text{kg/cm}^2$



Type A Type B

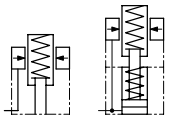

### 產品簡介

- 油壓支撐缸使用於機械加工時，減少振動，防止變形，以及吸收切削力，提升加工精度與品質。
- 油壓缸採用進口油封及零件，耐高壓，確保品質與使用壽命。
- 操作時充油速度不可太快，以避免接觸工件時，頂桿撞擊工件。
- HSP-16 螺柱式體積小，使用於夾具上，可在最小空間中排列使用。
- LSP-16B 低壓支撐缸，使用於低油壓系統，操作壓力  $50\text{kg/cm}^2$  以內即可獲得高壓之頂持力量。

### 型式簡介

- A型: 彈簧頂出型，頂桿伸出於最高頂出位置，工件接觸頂桿時由彈簧控制接觸力量，油壓操作充油將心軸鎖緊，而產生支撐力。
- B型: 油壓頂出型，頂桿於最低位置，由油壓操作充油時頂出，並以彈簧控制接觸工件力量，油壓持續加壓將心軸鎖緊而產生支撐力。

### 注意事項

- HSP-16 及 LSP-16B 頂桿螺帽，可依實際需要製作更換，頸部有一O型環為頂桿中心孔密封用，仍需加工裝配O型環，不得隨意丟棄。
- LSP-16B 如與其他治具用單動油壓缸，使用於同一套治具時，支撐缸迴路需單獨控制。



- 頂桿螺帽
- Nut on supporting arm

### Product Introduction

- The hydraulic supporting cylinder is normally applied for machining, which may reduce vibration, prevent deformation, absorb cutting force while upgrading machining accuracy and quality.
- The hydraulic cylinder employs imported oil seal and parts to resist high pressure, and ensure quality dependability and long service life.
- When operating the supporting cylinder, make sure do not exceed the normal oil feeding speed to avoid the supporting bar bumping against workpiece when it contacts workpiece.
- The HSP-16 screw type cylinder compact construction permits several units operated for clamping in a small space.
- The LSP-16B low pressure supporting cylinder achieves a high pressure supporting capability, hydraulic system and with in  $50\text{kg/cm}^2$  of operation pressure.

### Model Identification

- A Type: A spring ejecting type. The supporting bar is located at the highest position. The spring controls contact force when the workpiece is contacting the supporting bar. The hydraulic power actuates oil feeding for tightening the shaft, producing a supporting force.
- B Type: A hydraulic ejecting type. The supporting bar is located at the lowest position. The hydraulic power actuates oil feeding for ejecting. The spring controls contact force against the workpiece. The hydraulic power then tighten the shaft to produce a supporting force.

### Notice

- The supporting nut on the HSP-16 and LSP-16B can be replaced as shown on the figure right. An O-ring provided on the neck is used for sealing the center hole of supporting bar. The O-ring must be fitted, which should not be thrown away.
- When the LSP-16B uses the same single acting hydraulic cylinder with other jigs, the circuit for the supporting bar should be controlled individually when applying for the same jig.

# HSP 高壓支撐缸



## High Pressure Supporting Cylinder

• Rod:  $\phi 16$  mm • Pmax: 500kg/cm<sup>2</sup>

彈簧頂出型 **HSP-16A**  
Spring ejecting type

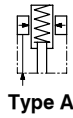

油壓頂出型 **HSP-16B**  
Hydraulic ejecting type

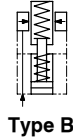

**HSP-16A**

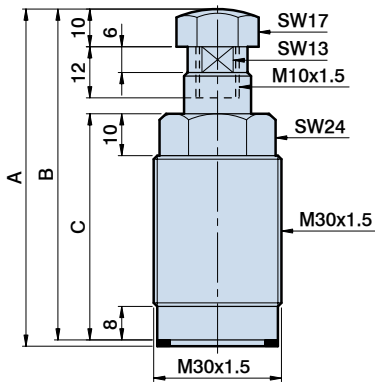

**HSP-16B**

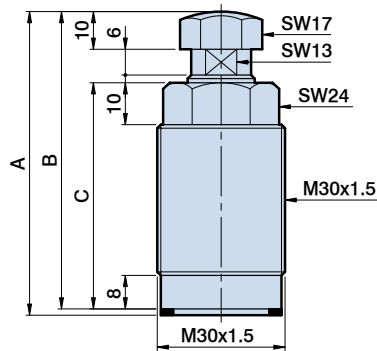

**HSP-16Base**

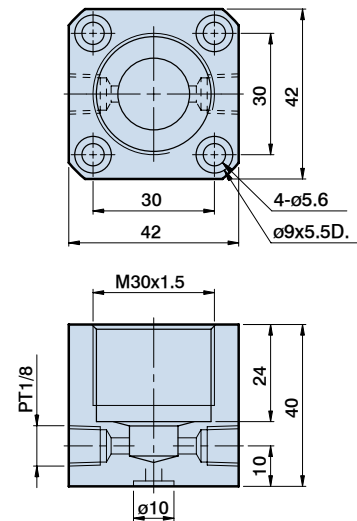

### 頂桿螺帽尺寸與適用型號 Rod nut sizes and applicable models

HSP-16A1 HSP-16B1  
HSP-16A2 HSP-16B2

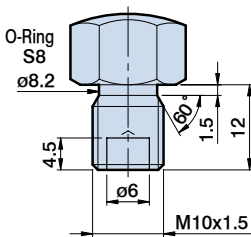

HSP-16B3  
HSP-16B4

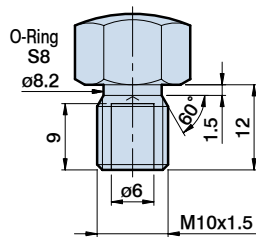

### 安裝底座示意圖 Mounting base diagram

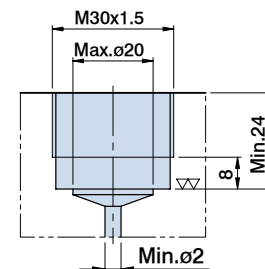

### Dimensional table

ITEM	MODEL	HSP-16A1	HSP-16A2	HSP-16B1	HSP-16B2	HSP-16B3	HSP-16B4
頂桿直徑 Rod size	mm	$\phi 16$		$\phi 16$		$\phi 16$	
頂桿行程 Rod stroke	mm	8		8		15	
最小操作壓力 Min. pressure		100Kg/cm <sup>2</sup>					
頂桿接觸工件力量 Rod force of touching work-piece		Min=0.8Kg Max=1.3Kg		Min=1Kg Max=2.3Kg		Min=1Kg Max=2.3Kg	
理論支撐力 Supporting force	500Kg/cm <sup>2</sup>	650Kg	950Kg	650Kg	950Kg	650Kg	950Kg
<b>A</b>	mm	80.5	90.5	72.5	82.5	79.5	89.5
<b>B</b>	mm	79	89	71	81	78	88
<b>C</b>	mm	54	64	54	64	61	71

# HSP 高壓支撐缸



## High Pressure Supporting Cylinder

• Rod:  $\phi 25\text{mm}$  • Pmax:  $500\text{kg/cm}^2$

### 特性資料 Specification

型號	Model	HSP-25A	HSP-25B
頂桿直徑	Rod size mm	$\phi 25$	
頂桿行程	Rod stroke mm	12	
最小操作壓力	Min. pressure	$100\text{Kg/cm}^2$	
頂桿接觸工作力量	Rod force of touching work-piece	Min=3Kg Max=5kg	
理論支撐力	Supporting force $500\text{Kg/cm}^2$	2000Kg	



Type A Type B

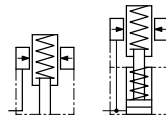

HSP-25A

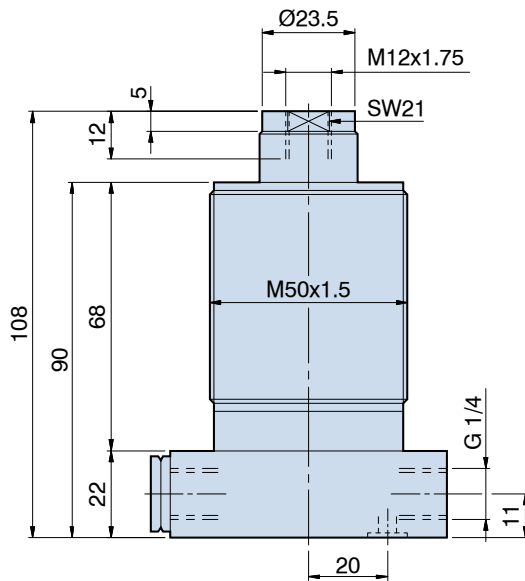

HSP-25B

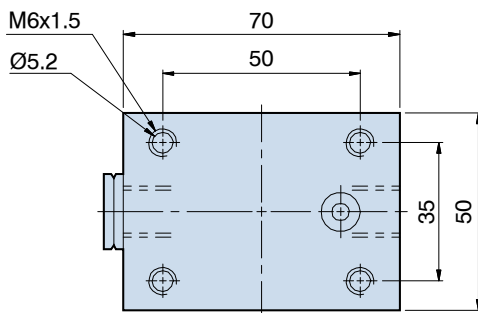
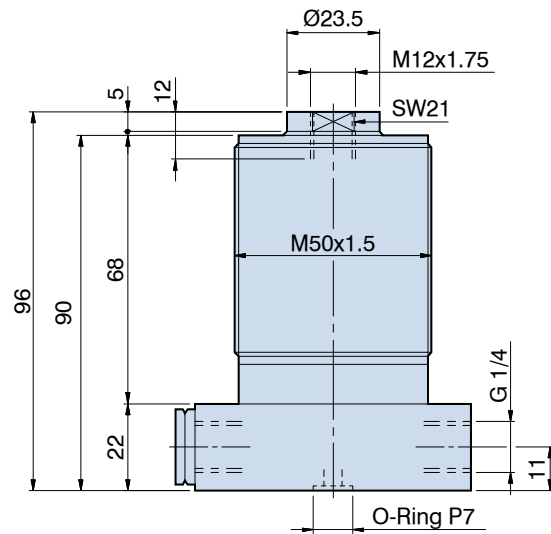

配管式 Line type	HSP-25A
油路板型 Manifold	HSP-M25A

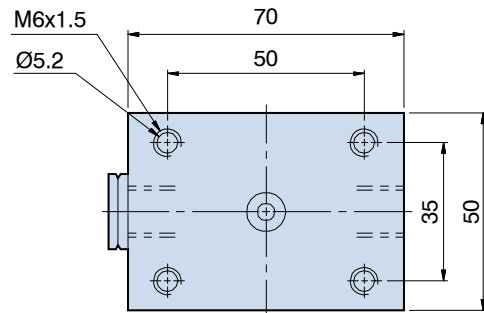

配管式 Line type	HSP-25B
油路板型 Manifold	HSP-M25B

# LSP 低油壓支撐缸



Low Pressure Supporting Cylinder

• Rod:  $\phi 16\text{mm}$  • Pmax:  $70\text{kg/cm}^2$

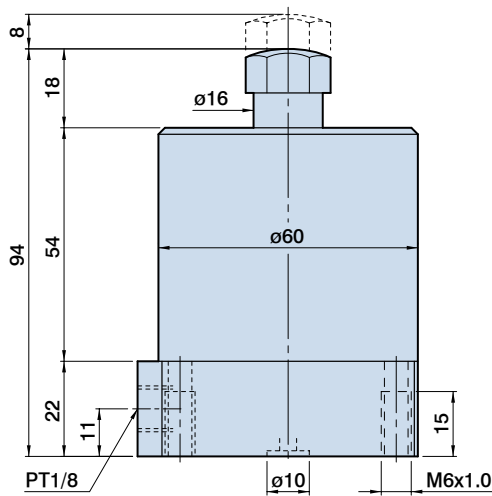
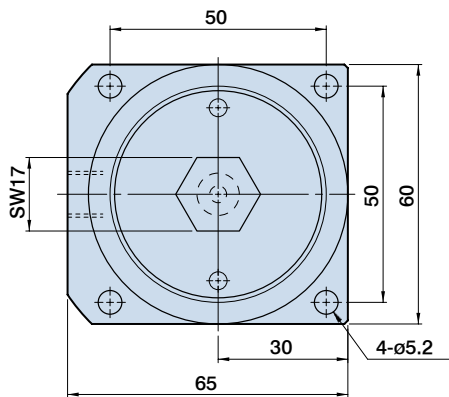

**LSP-16B 油壓頂出型  
Hydraulic extended  
piston rod**

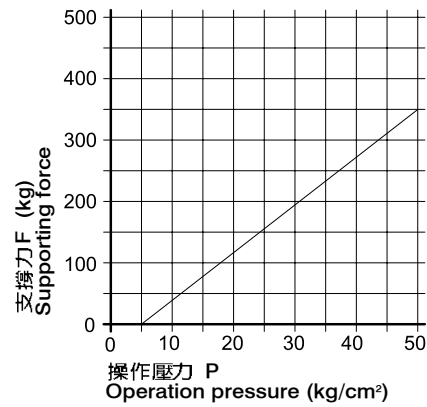

配管式 Line type	LSP-16B
油路板型 Manifold	LSP-M16B

